

# TECHNICAL SPECIFICATIONS

## CONNECTIONS



SINK

## APPLICATION



RESIDENTIAL



## PUMPING DISTANCE

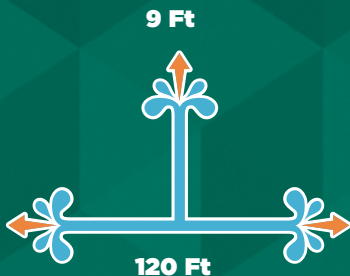

# Sanicompact® Comfort Macerator

## FULL VIEW OF BATHROOM



Example of installation. Follow local plumbing codes for actual install.

The **Sanicompact Comfort** is a **self-contained dual-flush toilet system** used to install a half-bathroom up to **9 feet below the sewer line, or even up to 120 feet away** from a soil stack. It incorporates a **macerating system** which can handle human waste and toilet paper in residential applications. The blade is made out of a hardened stainless steel material which **eliminates the need for any service or replacement**.

- **Discharges the waste through a 1" rigid pipe. A non-return valve is included** on the discharge elbow assembly provided with the system. This elbow can be rotated 360 degrees depending on the discharge installation.
- Has been designed with an internal one-way vent built into the system **which eliminates the need to have an external vent pipe**. Note: Check with your local plumbing codes for more information.
- The **standard dual flush version uses 1.28 gpf or 1 gpf (4.8 lpf or 3.8 lpf)**. This option allows using less water than any regular toilet but with the same efficiency. By pressing the push button, this activates a timer and a solenoid valve in order to fill and wash the sides of the bowl. The motor then starts and the waste and paper are sucked inside where it is macerated and pumped away. The timer is programmed to refill the bowl with fresh water after every cycle.
- Will also discharge **gray water from a sink**. The wastewater drains into a 1-1/4" hose connection in back of the toilet.

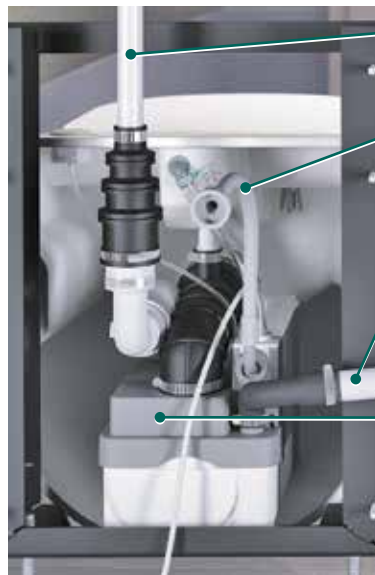

### Discharge Pipe

It only requires a 1" pipe. The system is provided with a discharge elbow with a built-in check valve.

### Water Supply

The system is provided with a water supply hose for easy connection. All that is needed is a 3/8" compression fitting (not included).

### Sink Drain

The system is provided with a rubber hose that connects to a 1-1/4" drainpipe. The system automatically discharges gray water independently from toilet operation.

### Sanicompact Comfort

Dual-flush tankless toilet system (1 gpf, 1.28 gpf/4.8 lpf, 3.8 lpf) is ideal for tight spots. Wall-hung toilet includes soft-close toilet seat and wall carrier with all the necessary mounting hardware.

# TECHNICAL SPECIFICATIONS

PLEASE CALL US TOLL-FREE AT  
**800-571-8191 (US) / 800-363-5874 (CDN)**  
 TO PURCHASE PARTS REFERENCED BELOW

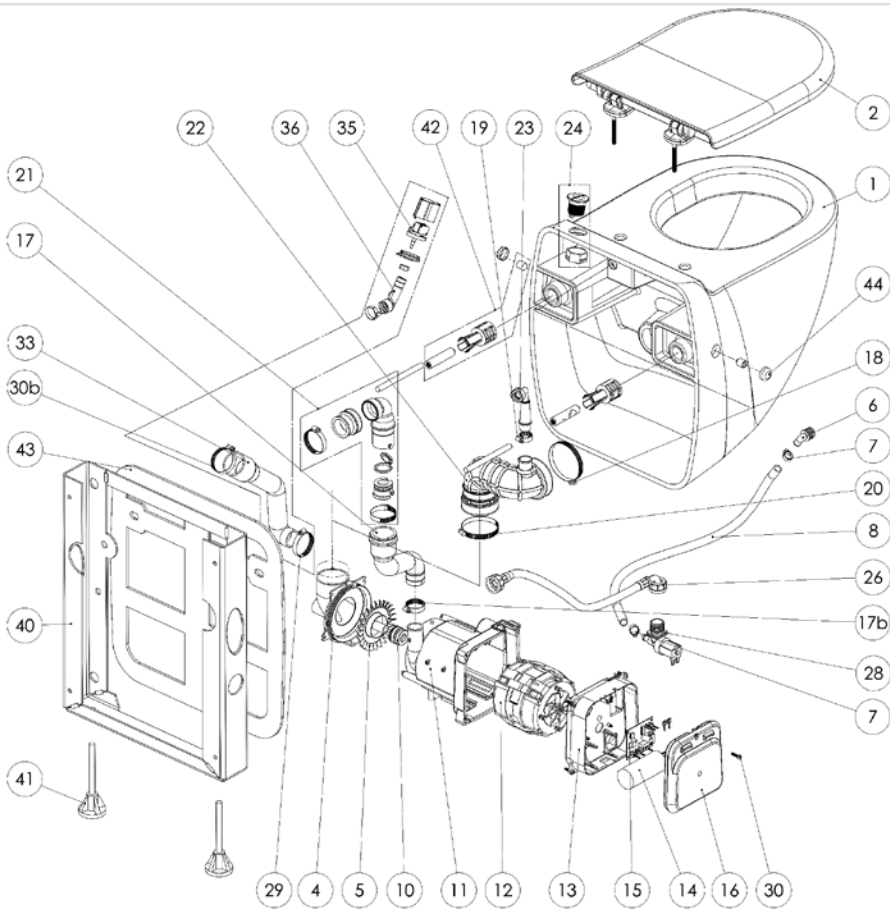

## DIMENSIONAL DRAWINGS

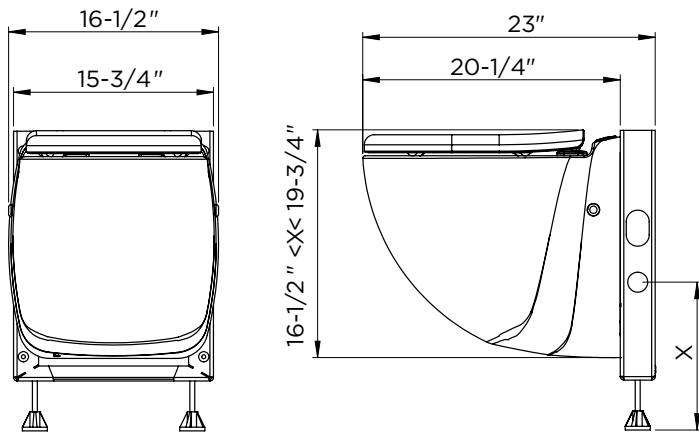

Choose any sink and enjoy your dream half-bathroom.

## TECHNICAL SPECIFICATIONS

### Pump type:

Macerator

### Electrical:

120 V - 60 Hz / 7.2 Amps (Max)

### Motor:

0.5 HP oil-filled thermally protected motor

### Capacitor rating:

45 microfarad

### Operating Temperature:

95°F (110°F Max.)

### Power cord length:

59 inches

### Noise level

≤ 53 dBA (Lp) (measured at 3 ft.)

### Discharge pipe diameter:

1"

### Discharge rate at 9 ft:

24 GPM

### Discharge rate at 3 ft:

31 GPM

### Normal running time:

24 sec (18 sec ECO mode)

### Capacity:

0.8 gallons / 0.3 liters

### Inlets:

1-1/4" sink connection (on motor case)

### Method of activation:

Push button / circuit board

### Weight:

72 lbs / 32.7 kg (Bowl with motor)

### Certifying agencies:

CSA (IPC, NSPC)

### Recommended accessories:

Descaler

### Connections:

Sink

